

AUTOMOTIVE CURRENT TRANSDUCER

DHAB S/38



Introduction

The DHAB family is best suited for DC, AC, or pulsed currents measurement in high power and low voltage automotive applications. Its contains galvanic isolation between the primary circuit (high power) and the secondary circuit (electronic circuit).

The DHAB family gives you a choice of having different current measuring ranges in the same housing (from ± 20 up to ± 600 A).

Features

- Open Loop transducer using the Hall effect sensor
- Low voltage application
- Unipolar + 5 V DC power supply
- Primary current measuring range up to ± 50 A for range 1 and from - 320 A to 450 A for range 2
- Maximum RMS primary admissible limited by the busbar, the magnetic core or the ASIC temperature $T^\circ < + 150^\circ\text{C}$
- Operating temperature range: $- 40^\circ\text{C} < T^\circ < + 125^\circ\text{C}$
- Output voltage: fully ratiometric (in sensitivity and offset) 2 measuring ranges to have a better accuracy.

Advantages

- Good accuracy for high and low current range
- Good linearity
- Low thermal offset drift
- Low thermal sensitivity drift
- Hermetic package.

Automotive applications

- Battery Pack Monitoring
- Hybrid Vehicles
- EV and Utility Vehicles.

Principle of DHAB Family

The open loop transducers uses a Hall effect integrated circuit. The magnetic flux density **B**, contributing to the rise of the Hall voltage, is generated by the primary current I_p to be measured.

The current to be measured I_p is supplied by a current source i.e. battery or generator (Fig. 1).

Within the linear region of the hysteresis cycle, **B** is proportional to:

$$B (I_p) = \text{constant} (a) \times I_p$$

The Hall voltage is thus expressed by:

$$V_H = (R_H/d) \times l \times \text{constant} (a) \times I_p$$

Except for I_p , all terms of this equation are constant. Therefore:

$$V_H = \text{constant} (b) \times I_p$$

The measurement signal V_H amplified to supply the user output voltage or current.

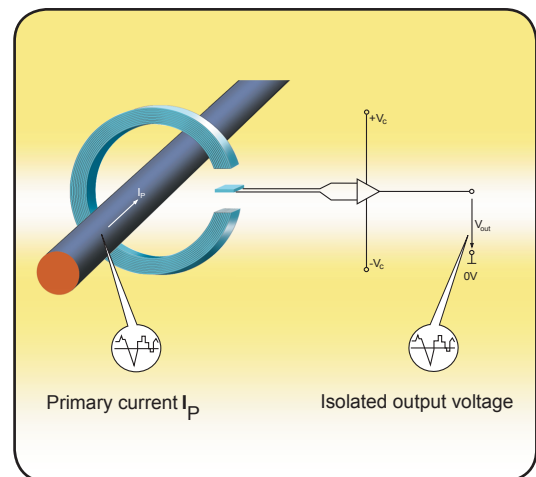

Fig. 1: Principle of the open loop transducer

DHAB S/38

Dimensions DHAB S/38 (in mm)

↓ (positive primary current direction)

16,5±0,25
24,4±0,25
64,5
21,55
11,5
31
39,5
14
6
34,75
14
6
Ø 3,4
See note 6
Ø 22,5
Ø 3,4
See note 6
-Logo LEM, -CE marking.

ELECTRICAL DIAGRAM

Components list

IC1	Hall sensor ASIC
IC2	Hall sensor ASIC
C1	Decoupling capacitor
C2	Decoupling capacitor
C3	Decoupling capacitor

Pin out

A	Channel 2
B	Vcc
C	Gnd
D	Channel 1

NOTES

- Sensor mates with Delphi GT150 connector p/n 15326815.
- Case material=PA66-25% glass reinforced.
- Terminals material=CuZn36 per NF EN 1652.Tin pre-plated finished 3-5µ.
- Estimated weight = 69,5 gr.
- Color = Black.
- Recommended max. torque for M3x0,5 screws = 1 Nm.
- Any sensor having undergone a fall of 20cm or more must be isolated.
- Fundamental tolerances in accordance with ISO system:

	<=3mm	3to6	6to10	10to18	18to30	30to50	50to80
Quality 14(I4ml)	250	300	360	430	520	620	740

DATE CODE

-PYYDDHHMMSS = Date code
 -P: Production center
 1=GENEVA / 7 =BEIJING
 -YY: Year on 2 digits
 -DDD: Day of the year
 -HH: Hour
 -MM: Minute
 -SS: Second

IDENTIFICATION CODE

-DHAB S/xx =sensor name / version.
 -.. = Identification code for jig.

PYYDDHHMMSS
DHAB S/xx
xx ..
PA66-GF25

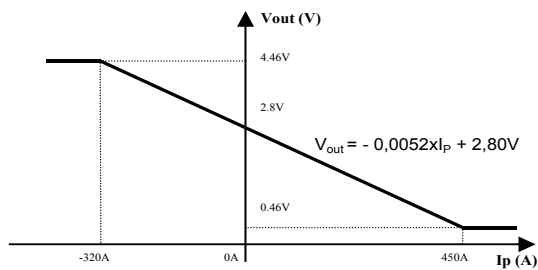

Bill of materials

- Plastic case >PA66-GF25<
- Magnetic core Channel 1: FeNi alloy
Channel 2: FeSi alloy
- Pins Brass tin plated
- Mass 69.5 g

Proposed Mating Connector

- DELPHI GT150 P/N 15326815

System architecture (example)

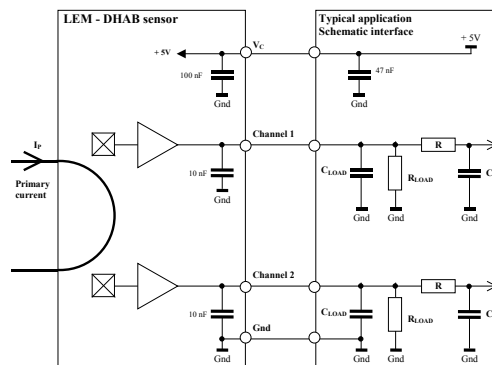

- $R_L > 10 \text{ k}\Omega$ optional resistor for signal line diagnosis
- $C_L < 100 \text{ nF}$ EMC protection
- RC Low pass filter EMC protection (optional)

DHAB S/38

Absolute maximum ratings

Parameter	Symbol	Unit	Specification			Conditions	
			Min	Typ	Max		
Electrical Data							
Supply voltage	V_C	V			8.5		
Over voltage						14	1 min
Reverse voltage			-14				1 min @ $T_A = 25^\circ\text{C}$
Output voltage (Analog)	V_{OUT}	V			8.5		
Output over voltage (Analog)		V			14	1 min @ $T_A = 25^\circ\text{C}$	
Continuous output current	I_{OUT}	mA	-10		10		
Output short-circuit duration	t_c	min			2		
Ambient storage temperature	T_S	$^\circ\text{C}$	-40		125		

Operating characteristics

Parameter	Symbol	Unit	Specification			Conditions
			Min	Typ	Max	
Electrical Data						
Supply voltage	V_C	V	4.5	5	5.5	
Output current (Analog)	I_{OUT}	mA	-1		1	
Current consumption	I_C	mA		15	20	
Power up inrush current						40
Load resistance	R_L	K Ω	10			
Capacitive loading	C_L	nF	1		100	
Ambient operating temperature	T_A	$^\circ\text{C}$	-10		65	High accuracy
			-40		125	Reduced accuracy

Channel 1

Parameter	Symbol	Unit	Specification			Conditions
			Min	Typ	Max	
Electrical Data						
Primary current	$I_{P \text{ channel } 1}$	A	-50		50	
Calibration current	I_{CAL}		-50		50	@ $T_A = 25^\circ\text{C}$
Offset voltage ¹⁾	V_O	V		2.5		@ $V_C = 5\text{ V}$
Sensitivity ¹⁾	G	mV/A		-40		@ $V_C = 5\text{ V}$
Resolution		mV		2.5		@ $V_C = 5\text{ V}$
Output clamping voltage min ¹⁾	V_{SZ}	V	0.24	0.25	0.26	@ $V_C = 5\text{ V}$
Output clamping voltage max ¹⁾			4.74	4.75	4.76	@ $V_C = 5\text{ V}$
Output internal resistance	R_{OUT}	Ω		1	10	
Frequency bandwidth	BW	KHz			1	@ -3 dB
Power up time		ms		25	110	
Setting time after over load		ms			25	

Channel 2

Parameter	Symbol	Unit	Specification			Conditions
			Min	Typ	Max	
Electrical Data						
Primary current	$I_{P \text{ channel } 2}$	A	-320		450	
Calibration current	I_{CAL}		-320		450	@ $T_A = 25^\circ\text{C}$
Offset voltage ¹⁾	V_O	V		2.80		@ $V_C = 5\text{ V}$
Sensitivity ¹⁾	G	mV/A		-5.2		@ $V_C = 5\text{ V}$
Resolution		mV		2.5		@ $V_C = 5\text{ V}$
Output clamping voltage min ¹⁾	V_{SZ}	V	0.24	0.25	0.26	@ $V_C = 5\text{ V}$
Output clamping voltage max ¹⁾			4.74	4.75	4.76	@ $V_C = 5\text{ V}$
Output internal resistance	R_{OUT}	Ω		1	10	
Frequency bandwidth	BW	KHz			1	@ -3 dB
Power up time		ms		25	110	
Setting time after over load		ms			25	

Note: ¹⁾ The output voltage V_{OUT} is fully ratiometric (concerning V_O , sensitivity and clamping) and is dependent on the supply voltage V_C relative to the following formula:

$$I_P = \left(V_{OUT} - \frac{V_C}{2} \right) \times \frac{1}{G} \times \frac{5}{V_C} \quad \text{with } G \text{ in } (V/A)$$

DHAB S/38

ACCURACY

Channel 1

Parameter	Symbol	Unit	Specification			Conditions
			Min	Typ	Max	
Electrical Data						
Electrical offset current	$I_{OE \text{ channel 1}}$	mA		± 100		@ $T_A = 25^\circ\text{C}$
Magnetic offset current	$I_{OM \text{ channel 1}}$	mA		± 50		@ $T_A = 25^\circ\text{C}$
Global offset current	$I_{O \text{ channel 1}}$	mA	- 300		300	@ $T_A = 25^\circ\text{C}$
			- 460		460	@ $- 10^\circ\text{C} < T^\circ < 65^\circ\text{C}$
			- 650		650	@ $- 40^\circ\text{C} < T^\circ < 125^\circ\text{C}$
Sensitivity error	ϵ_G	%		± 0.5		@ $T_A = 25^\circ\text{C}$
				± 2		@ $- 10^\circ\text{C} < T^\circ < 65^\circ\text{C}$
				± 3.5		@ $- 40^\circ\text{C} < T^\circ < 125^\circ\text{C}$
Linearity error	ϵ_L	%		± 0.5		off full range

Global Absolute Error (A)

Channel 1	Global Absolute Error (A)					
Temperature	-40	-20	0	25	65	125
Global Offset Error	± 0.53	± 0.46	± 0.39	± 0.30	± 0.44	± 0.65
Global Error @ $\pm 25\text{A}$	± 1.20	± 1.00	± 0.80	± 0.55	± 0.95	± 1.55
Global Error @ $\pm 50\text{A}$	± 2.04	± 1.69	± 1.34	± 0.90	± 1.60	± 2.65

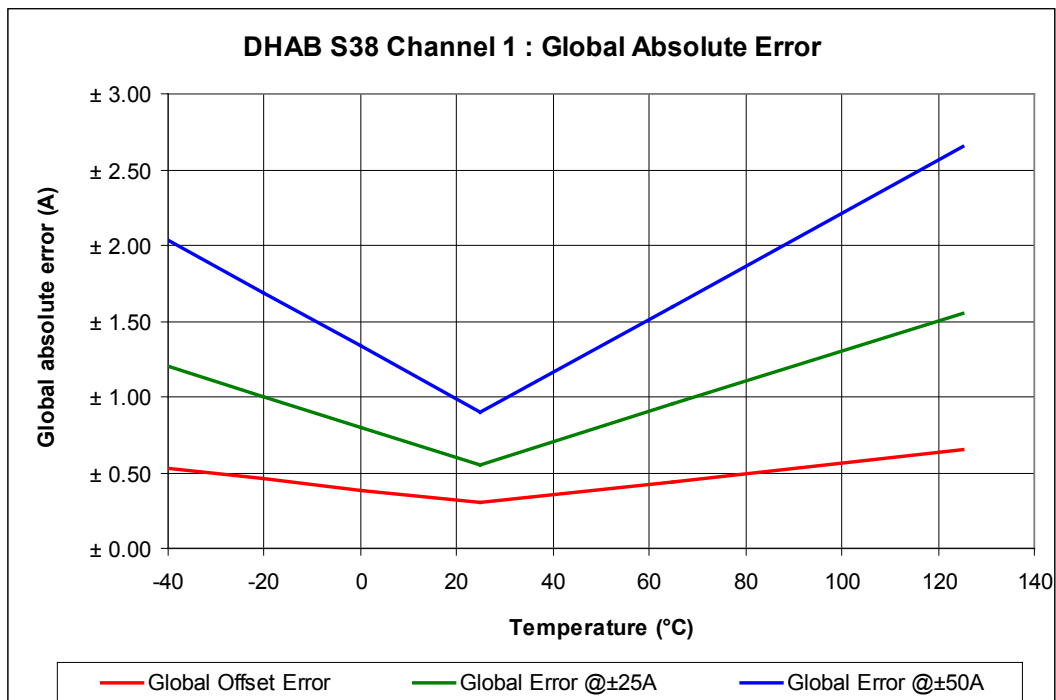

DHAB S/38

ACCURACY

Channel 2

Parameter	Symbol	Unit	Specification			Conditions
			Min	Typ	Max	
Electrical Data						
Electrical offset current	$I_{OE \text{ channel 2}}$	A		± 0.7		@ $T_A = 25^\circ\text{C}$
Magnetic offset current	$I_{OM \text{ channel 2}}$	A		± 2.5		@ $T_A = 25^\circ\text{C}$
Global offset current	$I_{O \text{ channel 2}}$	A	- 5		5	@ $T_A = 25^\circ\text{C}$
			- 5.5		5.5	@ $- 10^\circ\text{C} < T^\circ < 65^\circ\text{C}$
			- 6		6	@ $- 40^\circ\text{C} < T^\circ < 125^\circ\text{C}$
Sensitivity error	ϵ_G	%		± 0.5		@ $T_A = 25^\circ\text{C}$
				± 2		@ $- 10^\circ\text{C} < T^\circ < 65^\circ\text{C}$
				± 3.5		@ $- 40^\circ\text{C} < T^\circ < 125^\circ\text{C}$
Linearity error	ϵ_L	%		± 0.5		off full range

Global Absolute Error (A)

Channel 2	Global Absolute Error (A)					
Temperature	-40	-20	0	25	65	125
Global Offset Error	± 5.7	± 5.5	± 5.3	± 5.0	± 5.4	± 6.0
Global Error @ $\pm 200\text{A}$	± 10.8	± 9.8	± 8.8	± 7.5	± 9.5	± 12.5
Global Error @-320A to 450A	± 19.0	± 15.9	± 12.9	± 9.0	± 15.2	± 24.4

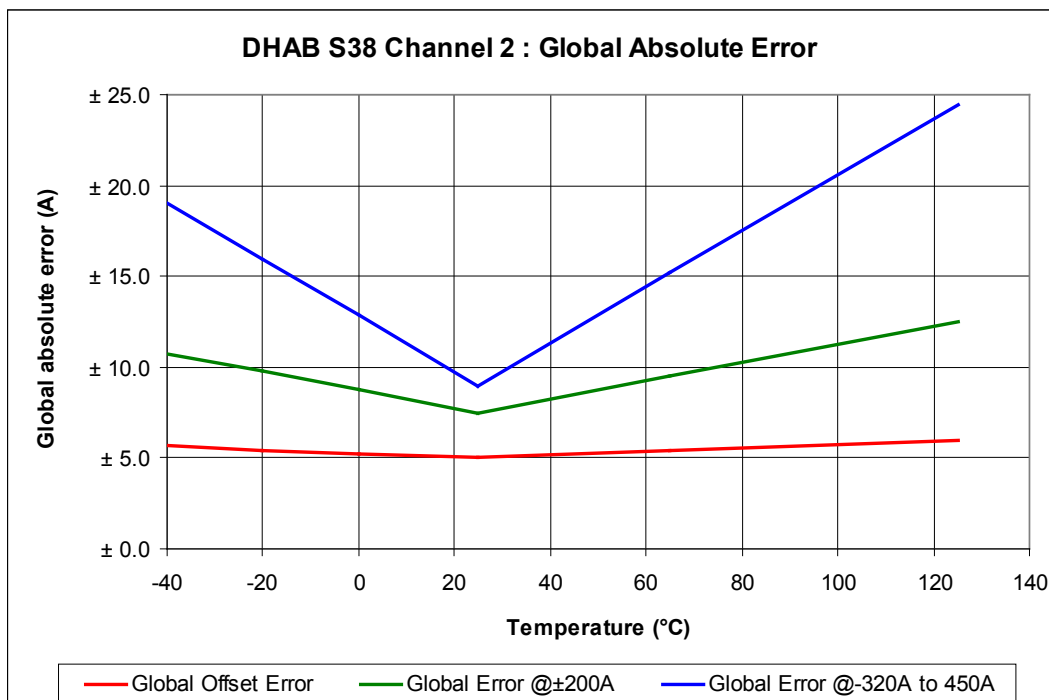

DHAB S/38

PERFORMANCES PARAMETERS DEFINITIONS

Output noise voltage:

The output voltage noise is the result of the noise floor of the Hall elements and the linear I_c amplifier gain.

Magnetic offset:

The magnetic offset is the consequence of an over-current on the primary side. It's defined after an excursion of $I_{P\ max}$.

Linearity:

The maximum positive or negative discrepancy with a reference straight line $V_{OUT} = f(I_P)$.

Unit: linearity (%) expressed with full scale of $I_{P\ max}$.

Linearity is measured on cycle + $I_{P\ O}$, - $I_{P\ O}$, + $I_{P\ O}$ without magnetic offset (average values used)

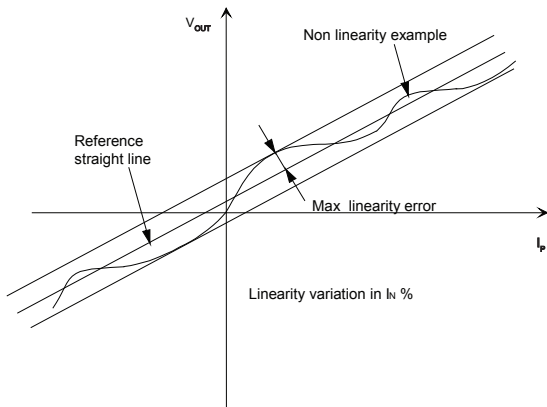

Response time (delay time) t_r :

The time between the primary current signal and the output signal reach at 90 % of its final value

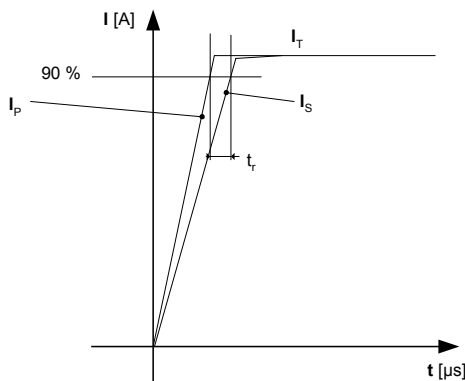

Typical:

Theoretical value or usual accuracy recorded during the production.

Sensitivity:

The Transducer's sensitivity G is the slope of the straight line $V_{out} = f(I_P)$, it must establish the relation:

$$V_{out}(I_P) = V_c/5 (G \times I_P + 2.5) (*)$$

(*) For all symetrics transducers.

Offset with temperature:

The error of the offset in the operating temperature is the variation of the offset in the temperature considered with the initial offset at 25°C.

The offset variation I_{OT} is a maximum variation the offset in the temperature range:

$$I_{OT} = I_{OE\ max} - I_{OE\ min}$$

The Offset drift TCI_{OEAV} is the I_{OT} value divided by the temperature range.

Sensitivity with temperature:

The error of the sensitivity in the operating temperature is the relative variation of sensitivity with the temperature considered with the initial offset at 25°C.

The sensitivity variation G_T is the maximum variation (in ppm or %) of the sensitivity in the temperature range:

$$G_T = (Sensitivity\ max - Sensitivity\ min) / Sensitivity\ at\ 25^\circ C.$$

The sensitivity drift TCG_{AV} is the G_T value divided by the temperature range.

Offset voltage @ $I_p = 0 A$:

Is the output voltage when the primary current is null. The ideal value of V_o is $V_c/2$ at $V_c = 5 V$. So, the difference of $V_o - V_c/2$ is called the total offset voltage error. This offset error can be attributed to the electrical offset (due to the resolution of the ASIC quiescent voltage trimming), the magnetic offset, the thermal drift and the thermal hysteresis.

Environmental test specifications

Name	Standard	Conditions
Thermal shocks	GM &5.5.5 (IEC 60068 Part 2-14)	T° - 40°C to 125°C / 300 cycles not connected.
		Criteria: $\epsilon_c < 3\%$ @ 25°C
Power temperature	GM &5.5.6 (IEC 60068 Part 2-14 Nb)	T° -40 + 125°C/595 cycles, supply voltage = 5 V
		Criteria: $\epsilon_c < 3\%$ @ 25°C
Temperature humidity cycle test	GM &6.18.1 (IEC 60068 2-38)	T° -10 + 65°C/10 cycles, supply voltage = 5 V
		Criteria: $\epsilon_c < 3\%$ @ 25°C
Mechanical tests		
Vibration test	GM &6.6.2 (IEC 60068 2-64)	Acceleration 30m/s ² , 25°C, frequency 20 to 1000 Hz/8h each axis
Drop test	GM &6.10 (IEC 60068 2-32)	Drop 1m, 2 falls/part, 1 part/axis, 3 axes, criteria: relative sensitivity error 3%
EMC Test		
Rms voltage for AC isolation test	GM &6.4-13 (IEC 60068 2-38)	
Bulk current injection immunity	ISO 11452-4	Criteria B
Electrostatic discharge immunity test		2 KV, Criteria B